

# Rack Mount/Table Top THC Analyzer

## Heated FID 5-100

The J.U.M. Engineering HFID Model 5-100 is a compact 19" rack mount or table top heated total hydrocarbon analyzer for high accuracy, sensitivity and stability for pressurized samples, using the conventional sample back pressure regulator technology.

The typical Application is the detection of low trace hydrocarbon impurities in high purity gases like CO<sub>2</sub>, N<sub>2</sub>, Ar, He, O<sub>2</sub> and others.



The Model 5-100 uses a hydrogen flame ionization detector (FID) in a heated oven to prevent the loss of high molecular weight hydrocarbons and to provide long term stability and reliable performance in the analysis of low trace concentration levels of hydrocarbon contaminants in high purity gases, air and other gases, including hydrogen.

To measure low trace total hydrocarbon impurities in 100% Hydrogen we offer our model H-100 FID analyzer.

## General:

For stack emissions applications in CEM's the 5-100 complies with US-EPA Method 25A and Method 503 (USA)

The J.U.M. Engineering HFID Model 5-100 is a compact 19" rack mount or table top heated total hydrocarbon analyzer for high accuracy, sensitivity and stability for pressurized samples with conventional sample back pressure regulator. The Model 5-100 is ideally suited for the detection of very low traces of hydrocarbons in pressurized high purity gases.

The 5-100 is also be well suited for the integration in continuous emissions monitoring systems (CEM) and other analytical systems which already are equipped with a complete sampling train and have a master sample pump.

The Model 5-100 uses a hydrogen flame ionization detector (FID) in a heated oven to prevent the loss of high molecular weight hydrocarbons and to provide long term stability and reliable performance in the analysis of low trace concentration levels of hydrocarbon contaminants in high purity gases, air and other gases, including hydrogen (Model H-100).

Except the sample back pressure regulator, all sample wetted components are integrated into the heated FID oven.



## 5-100 HFID Total Gaseous Organic Carbon Analyzer

### x Analyzer Features

- x Made in Germany
- x Heated oven FID, low priced, very economical
- x Low maintenance
- x Excellent long term stability
- x Conventional non-heated sample back pressure regulator (BPR)
- x Slim line design
- x Automatic flame out indicator with automatic fuel shut off valve
- x Fast response within 1 second
- x Low fuel and air consumption
- x Very selective on organic carbon
- x All heated components in temperature controlled oven, except BPR
- x Microprocessor PID type temperature controller for FID oven

### x Applications

- x Detection of low trace hydrocarbon levels in high purity gases as CO<sub>2</sub>, Ar, N<sub>2</sub>, He, O<sub>2</sub> and others
- x Inspection of high purity plumbing systems used in the semiconductor industry
- x Solvent recovery monitor of carbon bed break through
- x Catalytic converter testing
- x Carbon adsorption regeneration control
- x Hydrocarbon contamination monitoring in air and other gases
- x Clean room applications
- x Monitoring for VOC and/or Oil vapor break through after compressor air purifying systems

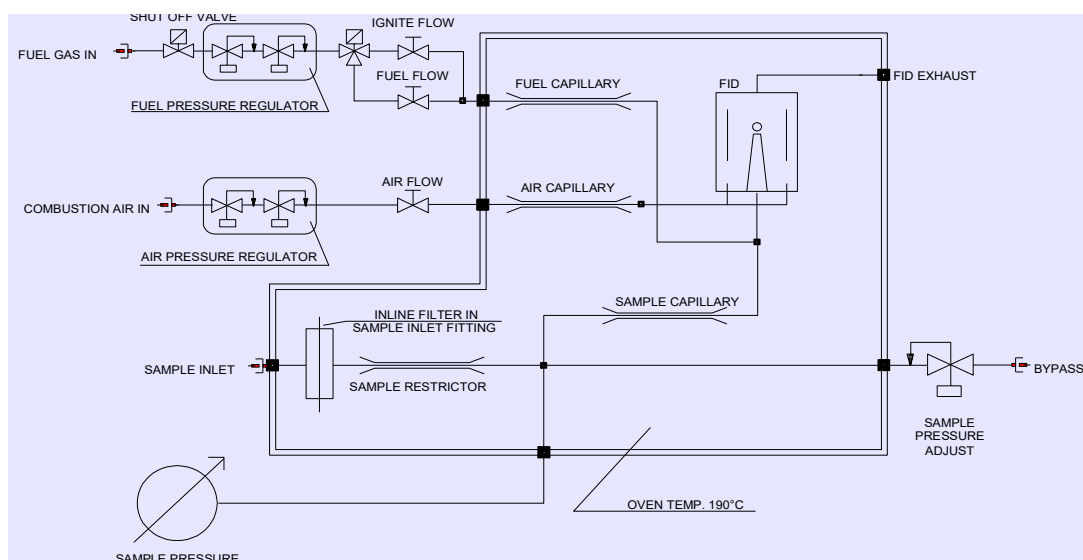

Complete flow diagram

## Principle of Operation

The Heated Flame Ionization Detection (HFID) method is used to determine the presence of total hydrocarbon concentrations in gaseous samples. Burning hydrocarbon-free hydrogen in hydrocarbon-free air produces a negligible number of ions in the detector. Once a sample which contains any organic carbon matter is introduced into this flame, a very complex ionization process is started. This process creates a large number of ions. A high polarizing voltage is applied between the two electrodes around the burner nozzle and produces an electrostatic field. Now negative carbon ions migrate to the collector electrode and positive hydrogen ions migrate to the high voltage electrode. The so generated ionization current between the two electrodes is directly proportional to the hydrocarbon concentration in the sample that is burned by the flame. This signal is measured and amplified by a highly sensitive and stable electrometer amplifier unit.

Our proprietary sample pressure regulator provides a controlled sample pressure and flow which gives admittance of a constant sample flow rate to the FID burner. This technique of using our non sample contact regulator is time proven for over 40 years by J.U.M. Engineering to provide the highest possible sample low flow rate stability at the lowest maintenance. Our compactly designed flow control module for fuel, ignition and air flow rates via low thermal mass needle valves use high precision pressure regulators. The needle valves are factory adjusted and sealed to ensure the optimization of the burner.

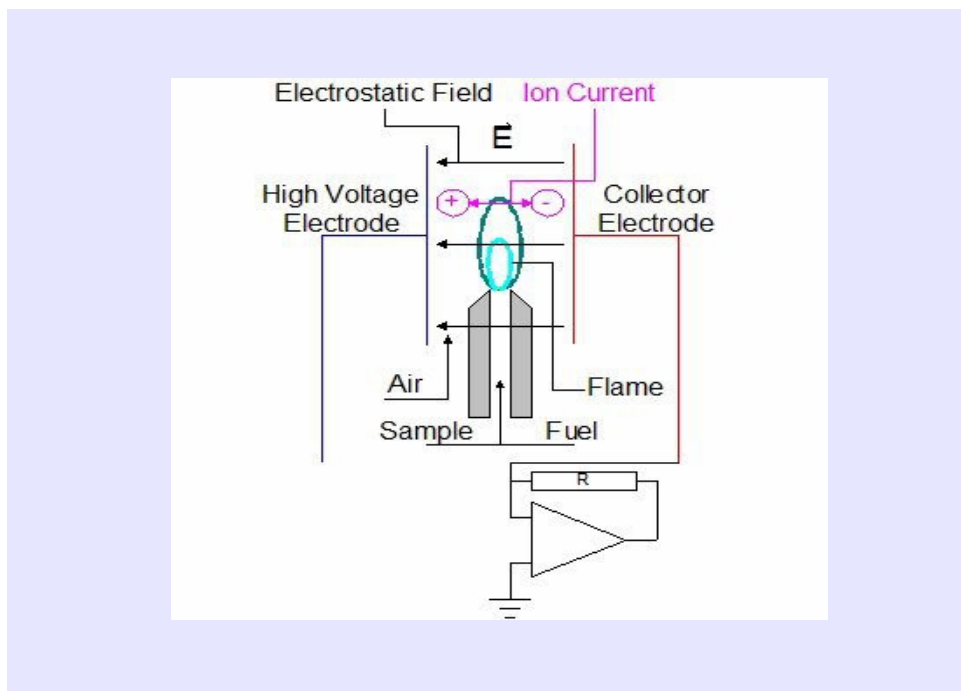

## 5-100 HFID Total Gaseous Organic Carbon Analyzer

### Technical Specifications

Method	Heated Flame Ionization Detector (HFID)
Sensitivity	Max. 1 ppm CH <sub>4</sub> full scale with low trace module
Response time	@ sample inlet <0.8 seconds @ 3 LPM sample flow
t <sub>90</sub> time	@ sample inlet <1.4 seconds
Zero drift	<2% full scale / 24h
Span drift	<2% full scale / 24h
Linearity	Up to 10.000 ppm full scale within 1.5%
Oxygen synergism	< 2% FSD
Measuring ranges (ppm)	0-1 (optional), 0-10,100, 1.000, 10.000, 100.000, others on request. Front panel turn switch. Automatic or remote range change optional
Concentration Display	3.5 -digit DVM, Optional direct reading ppm units. 24 bit high resolution. measure up to 3 overlapping ranges without range change
Signal outputs	0-10 VDC, 4-20 mA, Optional RS-232 data output
Total sample flow through	Between 0.8 to 3 l/min capacity @ operating temp.
Sample filter	Permanent miniature 2 micron mesh mounted in sample inlet fitting
Zero and span adjust	Manual duo dial on front panel
Fuel gas choice	1. Standard 100% H <sub>2</sub> , consumption approx. 20 ml/min 2. Optional 40%H <sub>2</sub> /60%He, consumption approximately 90 ml/min 3. Optional 40%N <sub>2</sub> /60%He, consumption approximately 90 ml/min
Burner air consumption	Approx. 130 ml/min of synthetic air, 200 ml/min at mixed fuel gas
Oven temperature	190°C (374°F), digital PID controller
Power requirements	230VAC/50Hz, 850 W. 120 VAC/60Hz optional
Ambient temperature	5-43°C (41-110°F)
Dimensions (W x D x H)	19" (483 mm) x 460 mm x 132 mm
Weight	approx. 18 kg (50 lbs)

### Available Options

AMU 51	Automatic controlled range change with range identification
AZM 51	Automatic flame ignition and re-ignition
ENGA 51	<b>6-digit engineering units display 0-100.000 ppm with RS232 data output.</b>
LTO 51	Measurement of low trace hydrocarbon levels.
RCA 51	0-20mA analog output instead of 4-20mA
RCIO 51	0-20 mA analog output, galvanic isolated
RCI4 51	4-20 mA analog output, galvanic isolated
TPR 51	External temperature controller for J.U.M. heated sample lines Model TJ 100

J.U.M. reserves the right, at any time and without notice, to change specifications presented in this data sheet and assumes no responsibility for the application or use of the devices described herein.

### J.U.M.® Engineering GmbH

Gauss-Str. 5, D-85757 Karlsfeld, Germany  
Tel.: 49-(0)8131-50416, Fax: 49-(0)8131-98894  
E-mail: [info@jum.com](mailto:info@jum.com)  
Internet: [www.jum.com](http://www.jum.com)

© J.U.M. Engineering 2014/2020  
1<sup>st</sup> Print Date: January 2020