

Rack Mount/Table Top THC Analyzer TVOC Heated FID VE 7

The VE7 19"/5PU rack mount and table top heated emission analyzer for the continuous determination of the mass concentration of total gaseous organic carbon using the Flame Ionization Detector Method.

Throughout the EU the VE7 complies with QAL1 (EN 14181-EN ISO 14659), with EN 12619:2013 and in USA with EPA Method 25A and Method 503



****Low cost of ownership. **Low fuel gas consumption.
The combustion air supply for the FID-detector is built in. No external cylinder for synthetic air is needed. **To prevent well known HC hang up (memory effect) and related drifting, the heated sample line can easily be connected inside of the heated oven. This prevents any cold spot and any related HC condensation.

General:

Confirmed by TÜV-Nord (Germany) to comply with EN 14181 and EN ISO 14956U). Complies with EN 12619:2013 (EU) and US-EPA Method 25A and Method 503 (USA)

With many thousand's of units sold, the VE7 is our mostly distributed, most robust and cost effective heated FID analyzer in source and stack testing worldwide

The J.U.M. Engineering HFID Model VE7 is time proven in an over 40 years. It is a highly reliable and outstandingly rugged 19" rack mount or table top heated total hydrocarbon (total gaseous organic carbon) analyzer. Built for very low drift, high accuracy, sensitivity and stability. The VE7 uses a hydrogen flame ionization detector (FID) in a heated oven to prevent the loss of high molecular weight hydrocarbons and to provide reliable performance in the analysis of high concentrations down to very low trace concentration levels of gaseous organic carbon contaminants in emissions, air and other gases and high purity gases.

All sample containing parts and components are discretely integrated into the heated chamber. The permanent heated sample filter is cleaned by back purging with compressed air or nitrogen. This allows uninterrupted measurements during cleaning the sample filter. While back purging the sample filter, the external sample line and sample probe is also cleaned. The use of a stack probe filter is not necessary when the FID is used in a stand alone mode.

The combustion air supply for the detector is built in. No expensive zero gas generator or external cylinder for synthetic air is needed. The proprietary rear panel sample line adapter-plate system allows cold-spot free coupling of a heated sample line inside of the heated oven without the need of special tools. The fittings can easily be accessed through a wrench port in the right side panel.

Standard analyzer is optimized to comply with EN-12619:2013 specifications. Several target optimizations for non EN-12619:2013 applications available.



Analyzer Features

1. Made in Germany
2. **1st Sampling Choice:** Maintenance free, permanently installed sample filter back purge system allows filter to be cleaned without dismantling (automatic back purge optional)
3. **2nd Sampling Choice:** Disposable sample filter which is easily accessible in the rear panel without special tools. This optional available feature is an approx. This reflects a 20% price advantage.
4. All components in contact with sample are fully heated and digitally maintained at 190° C
5. Built-In sample pump
6. Built-in combustion air supply, no extra burner air bottle needed
7. Permanent 2 micron stainless mesh sample filter or 2 micron disposable sample filter
8. "Overflow" calibration system for safe zero and span calibration
9. Automatic flame out alarm contact and optional available fuel shut off valve
10. Fast response less than 1 second @ sample inlet
11. Low fuel consumption @ 100% or 40/60 mixed fuel gases
12. Microprocessor PID type temperature controller
13. Cold spot free coupling of a heated sample line inside the heated oven with optional Adapter Plate (Works not with OVE Option)
14. Remote control for sample, zero gas, span gas and back purge is standard
15. Automatic or remote range change optional

Applications

1. Compliance monitoring of source hydrocarbons following European EN 14181/ EN ISO 14659, EN 12619:2013 regulations and USA EPA Method 25A
2. Stack gas hydrocarbon emissions monitoring
3. Fence line (perimeter) monitoring
4. Solvent recovery monitor for carbon bed break through
5. Catalytic converter and thermal combustion testing
6. Carbon adsorption regeneration control
7. Measuring engine combustion efficiency
8. Raw exhaust vehicle emissions analysis
9. Hydrocarbon contamination monitoring in air and other gases
10. Detection of trace hydrocarbons in purity gases used in the semi conductor industry
11. LEL monitor of solvent laden air

Principle of Operation

The Heated Flame Ionization Detection (HFID) method is used to determine the presence of total hydrocarbon concentrations in gaseous samples. Burning hydrocarbon-free hydrogen in hydrocarbon-free air produces a negligible number of ions in the detector. Once a sample which contains any organic carbon matter is introduced into this flame, a very complex ionization process is started. This process creates a large number of ions. A high polarizing voltage is applied between the two electrodes around the burner nozzle and produces an electrostatic field. Now negative carbon ions migrate to the collector electrode and positive hydrogen ions migrate to the high voltage electrode. The so generated ionization current between the two electrodes is directly proportional to the hydrocarbon concentration in the sample that is burned by the flame. This signal is measured and amplified by a highly sensitive and stable electro-meter-amplifier unit. Our proprietary sample pressure regulator provides a controlled sample pressure and flow which gives admittance of a constant sample flow rate to the FID burner. This technique of using our non sample contact regulator is time proven for over 40 years by J.U.M. Engineering to provide the highest possible sample low flow rate stability at the lowest maintenance. Our compactly designed flow control module for fuel, ignition and air flow rates via low thermal mass needle valves use high precision pressure regulators. The needle valves are factory adjusted and sealed to ensure the optimization of the burner.

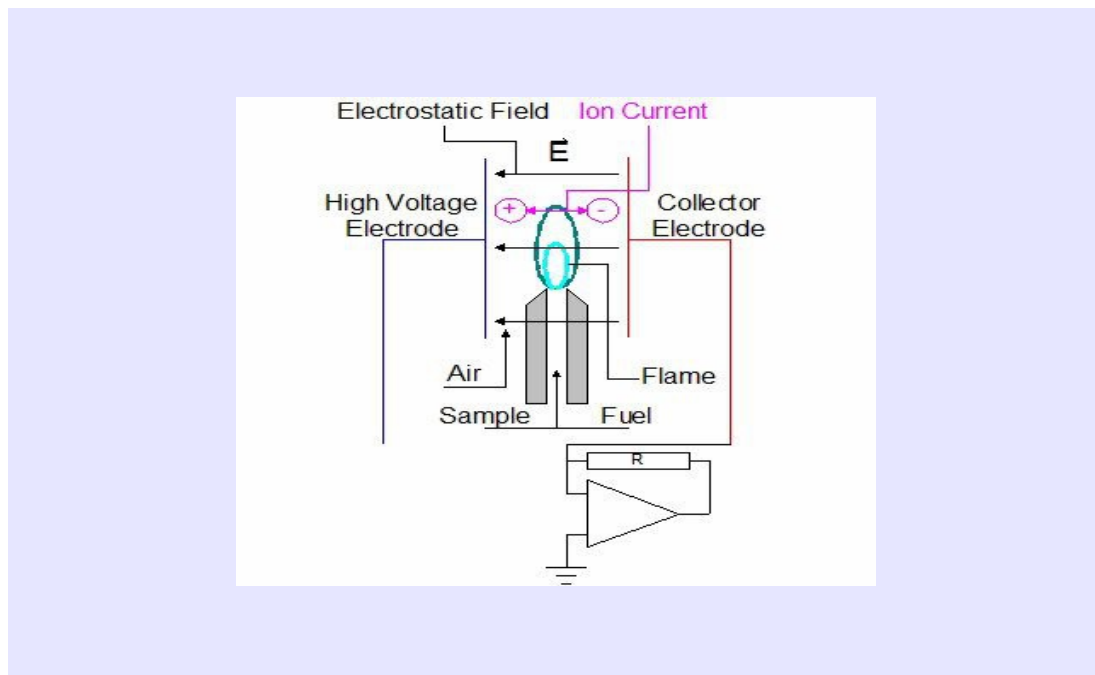

VE7 Heated FID Total Gaseous Organic Carbon Analyzer

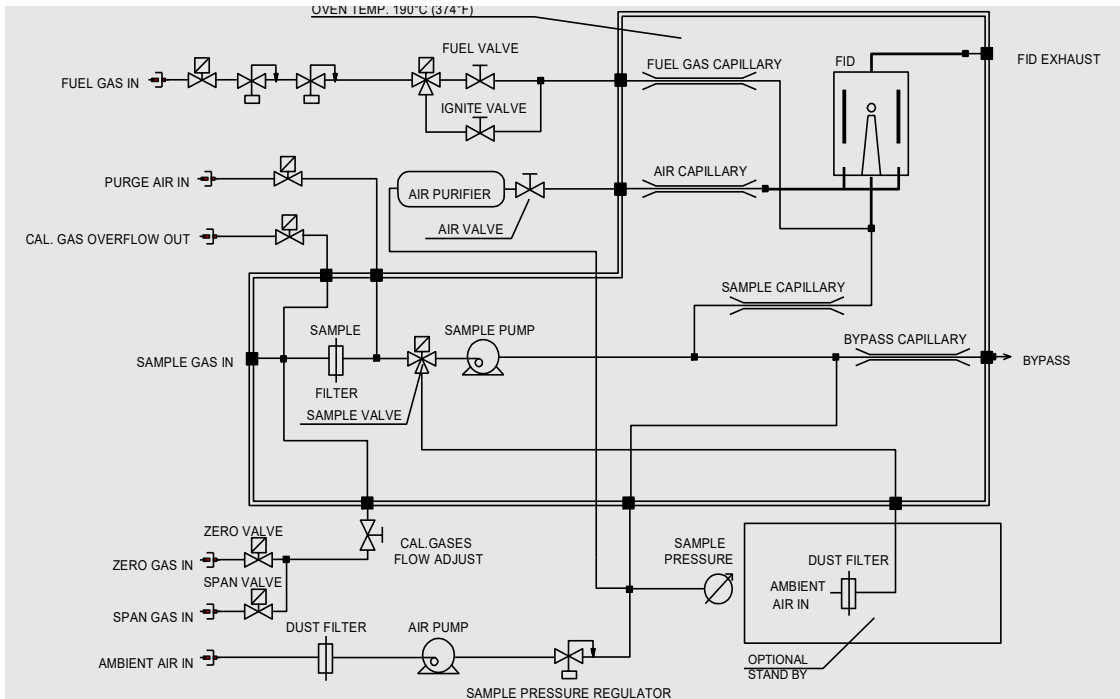

Complete Flow Diagram shown with Back Purge Sample Filter

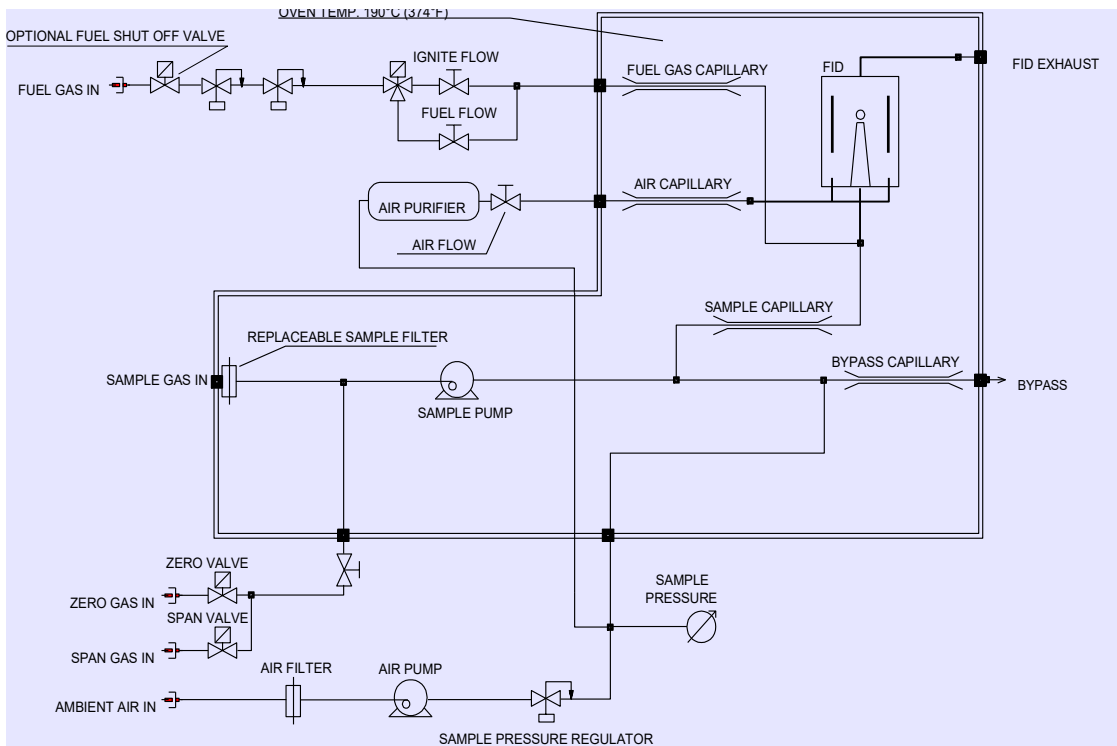

Complete flow diagram shown with alternative disposable sample filter Option OVE 7

Technical Specifications

Method	Heated Flame Ionization Detector (HFID)
Sensitivity	Max. 1 ppm CH ₄ full scale
Response time	@ sample inlet <0.2 seconds
t₉₀ time	@ sample inlet <1.2 seconds
t₉₀ time including 4X6mm sample line	Including heated sample line (7.5m) and sample probe filter filter: less than 8 seconds
Zero drift	<2% full scale / 24h
Span drift	<2% full scale / 24h
Linearity	Up to 10.000 ppm full scale within 1.5%
Oxygen synergism	< 2% FSD
Measuring ranges (ppm)	0-10, 100, 1,000, 10,000, 100,000, others on request. Front panel turn switch, automatic or remote optional, and
Signal outputs	0-10 VDC, 4-20 mA, including RS-232 data output
Display	6- digit direct reading ppm units capability to measure 3 overlapping ranges without range change
Total sample flow through	2.5 to 2.8 l/min capacity @ operating temp.
Sample filter	Permanent 2 micron mesh filter, cleaned by back purge with compressed dry air or N ₂ . Alternatively disposable change filter in rear panel. Option OVE 7.
Zero and Span gas	Front panel switch selectable and remote control, gas inlets on rear panel
Zero and span adjust	Manual duo dial on front panel
Fuel gas choice	<ol style="list-style-type: none"> 1. Standard 100% H₂, consumption approx. 20 ml/min 2. Optional 40%H₂/60%He, consumption approximately 90 ml/min 3. Optional 40%N₂/60%He, consumption approximately 90 ml/min
Burner air consumption	Built in burner air supply. No external cylinder air needed. consumption approximately 130 ml/min. At 40/60 mixed fuels. Air consumption is approx. 220 ml/min
Oven temperature	190°C (374°F)
Temperature control	micro-processor PID controller
Power requirements	230VAC/50Hz, 850 W. 120 VAC/60Hz optional
Ambient temperature	5-43°C (41-110°F)
Dimensions (W x D x H)	19" (483 mm) x 460 mm x 221 mm
Weight	approx. 22 kg (50 lbs)

Available Options

OVE 75	Quick change disposable 2 micron sample filter housed in the heated oven instead of back purge sample filter. (Over 2.500,-- Euro Price Advantage!)
OWM 7	Wall or Panel Mount Adapted System allows the analyzer to be installed on a wall, a panel, or inside of an outdoor or safety purged enclosure ****
AMU 7	Automatic controlled range change with range identification
APO 7	Automatic sample filter pack purge; Internal, easily programmable back purge timing system for back purge time and purge sequence sequence
AZM 7	Automatic flame ignition and re-ignition
DCC 7	Dual concentration alarm w. individual adjustable thresholds and alarm outputs
ENGA 7	6-digit engineering units display 0-100.000 ppm (or others) with RS232 data output. 24 bit resolution allows to digitally measure throughout 2 to 3 measuring ranges without range change
FOAS 7	Flame out control with automatic fuel shut off valve
HBPR 7 *	Fully heated sample back pressure regulator allows to run analyzer in closed loop sampling mode
ICM 7 **	Built-in NMHC Cutter, measure either THC or Methane-Only concentrations with one analyzer
LTO 7	Measurement of low trace hydrocarbon levels. Requires external, zero grade combustion air supply
MBP 7 ***	Integrated bypass pump for very long sample lines, also compensates sample pressure fluctuations at sample inlet
PDA 7	Sample pressure monitor with alarm
RCA 7	0-20mA analog output instead of 4-20mA
RCC 7	Remote controlled range change with range identification (dry contact)
RCIO 7	0-20 mA analog output, galvanic isolated
RCI4 7	4-20 mA analog output, galvanic isolated
TPR 7	Built in temperature controller for J.U.M. heated sample lines Model TJ 100 or other with "J" type thermocouple

- Important!**
1. * HBPR cannot be combined with ICM or MBP
 2. ** ICM cannot be combined with LTO
 3. *** MBP cannot be combined with ICM
 4. ***When equipped with OWM 7 analyzer design is upright. The dimensions are (W x D x H) 383 mm (19") x 221 mm x 700 mm

J.U.M.® Engineering GmbH

Gauss-Str. 5, D-85757 Karlsfeld, Germany

Tel.: 49-(0)8131-50416, Fax: 49-(0)8131-98894

E-mail: info@jum.com

Internet: www.jum-aerosol.com

© J.U.M. Engineering 2014/2015
1st Print Date: February 2016